

PARTS LIST

Backup Sensor Attachment Kit P/N 08V67-T0A-100

Control unit

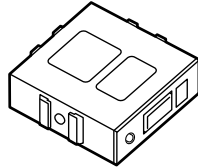

Buzzer



Switch

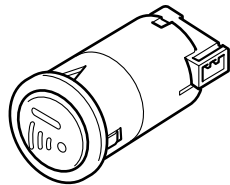

Backup sensor harness

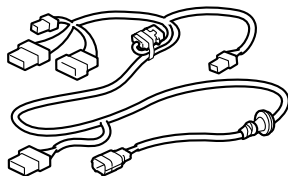

Subharness

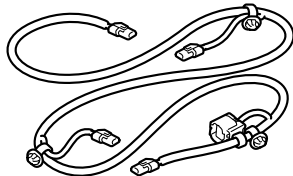

Control unit bracket

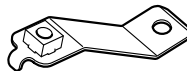

Right corner sensor clip (Black)

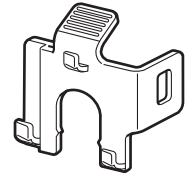

Left corner sensor clip (White)

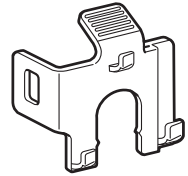

Right center sensor clip (Gray)

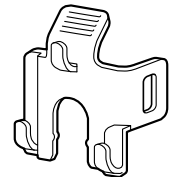

Left center sensor clip (Yellow)

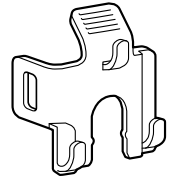

Switch bracket

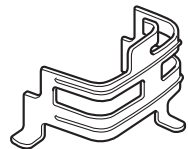

5 Wire ties

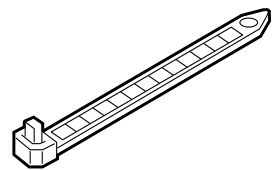

Narrow wire tie

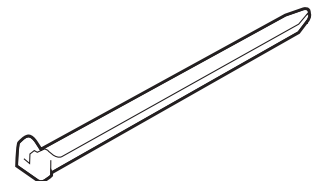

3 Wire ties with clips A
(Some may not be used)

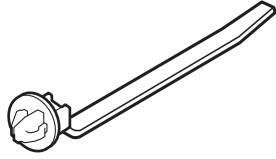

Wire tie with clip B
(May not be used)

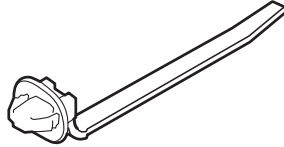

Flange bolt

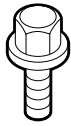

Fuse label



7 Aluminum tapes



2 Urethane tapes

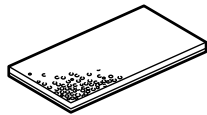

Clip



Accessory User's Information Manual

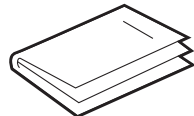

Backup Sensor Kit

NOTE: Refer to the Parts Information Bulletin (PIB) for the proper color sensors.

Left corner sensor

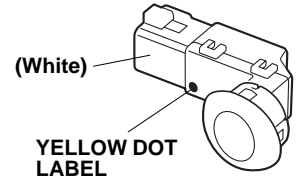

Right corner sensor

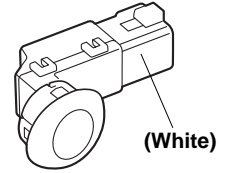

Left center sensor

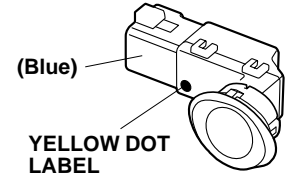

Right center sensor

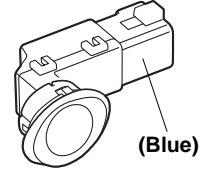

TOOLS AND SUPPLIES REQUIRED

Phillips screwdriver
Small flat-tip screwdriver
10 mm Open end wrench
10 mm and 14 mm Sockets
Pushpin
Ratchet
3 mm Drill bit
Eye protection (face shield, safety goggles, etc.)
File
Scissors
Ruler
Blanket
Isopropyl alcohol
Shop towel
24 mm and 26 mm Hole saws
Drill
Trim Tool Set (T/N SOJATP2014)
Tape
Diagonal cutters
Felt-tip pen
Utility knife
Rubber mallet

Available through the Honda Tool and Equipment program. On the iN, click on: Service/Service Bay/Tool and Equipment Program, then enter the number under "Search." Or call 888-424-6857.

Illustration of the Backup Sensors on the Vehicle

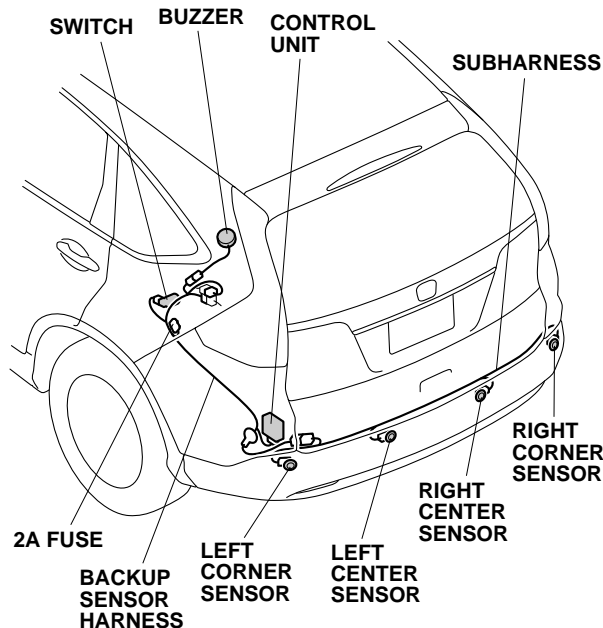

INSTALLATION

Customer Information: The information in this installation instruction is intended for use only by skilled technicians who have the proper tools, equipment, and training to correctly and safely add equipment to your vehicle. These procedures should not be attempted by "do-it-yourselfers."

1. Disconnect the negative cable from the battery.
2. If equipped, remove the tonneau cover (compress the spring-loaded end, and remove).

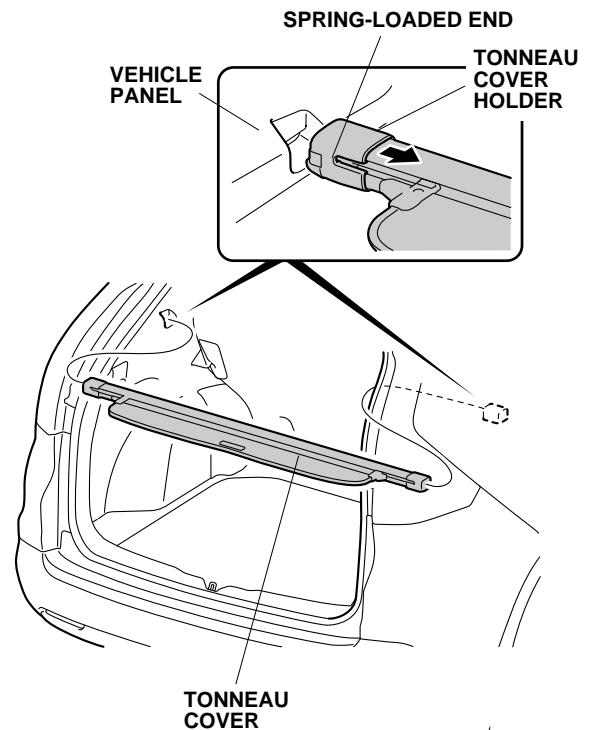

3. Pull the lever, and fold down the left rear seat.

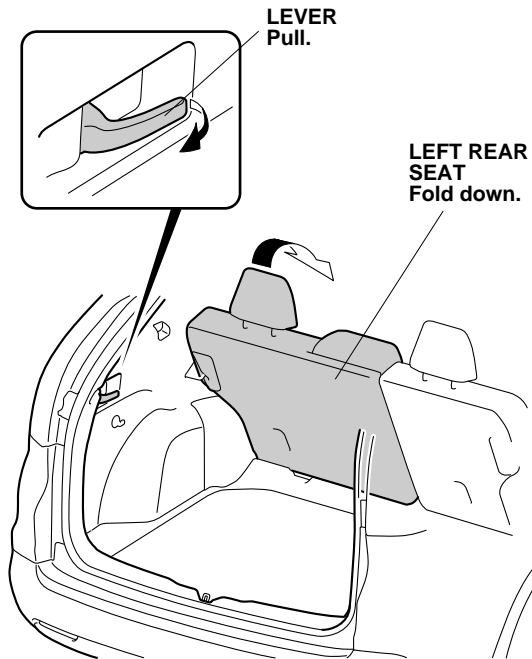

4. Lift the left rear seat-back.

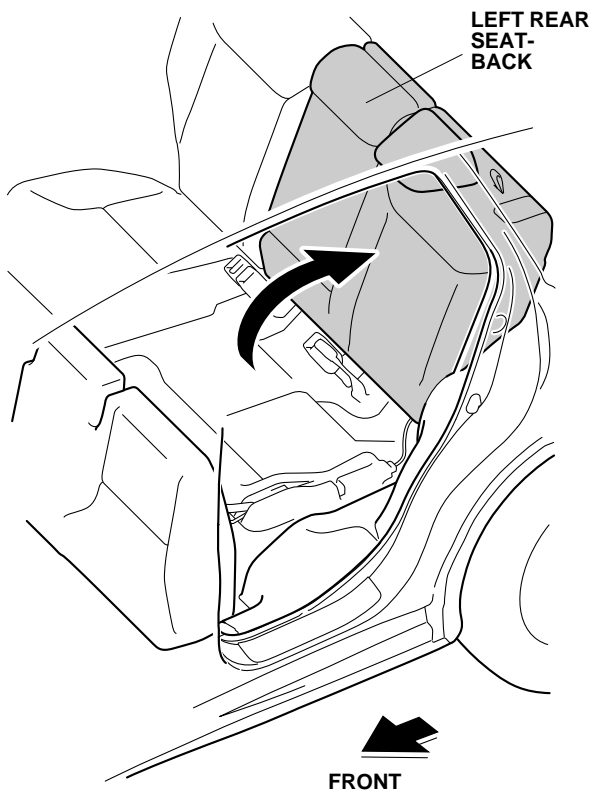

5. Remove the left rear door sill trim (three clips, five retaining tabs, and one hook).

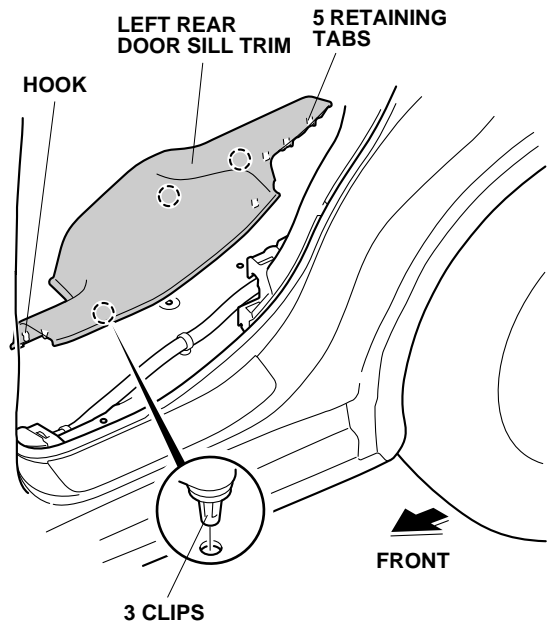

6. Pull the lever, and fold down the left rear seat back.
7. Remove the cargo area floor (two hooks).

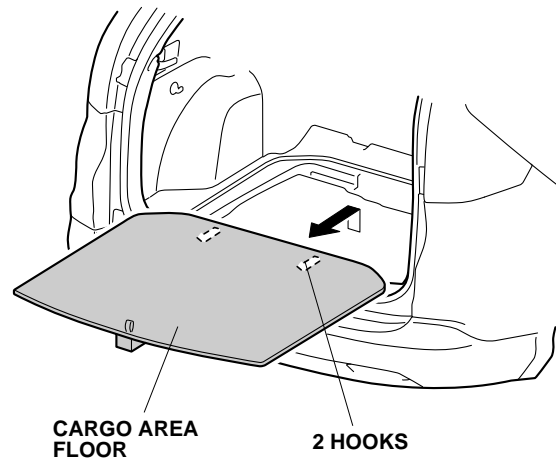

8. Pull away the weatherstrip. Remove the rear trim panel (two retaining tabs, six clips, and two hooks).

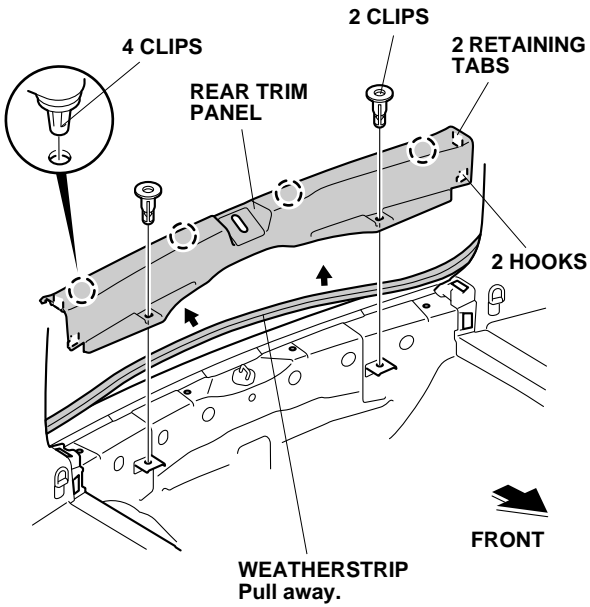

9. Remove the left rear damper cover (seven retaining tabs, four hooks, and lift up).

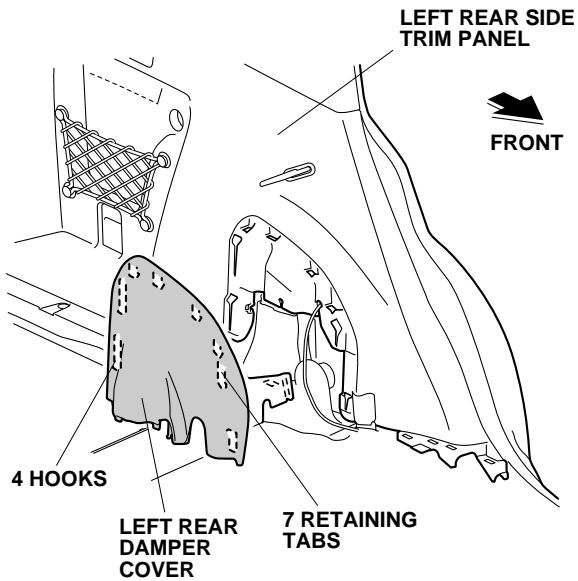

10. Release the floor carpet from the left carpet cover (three clips).

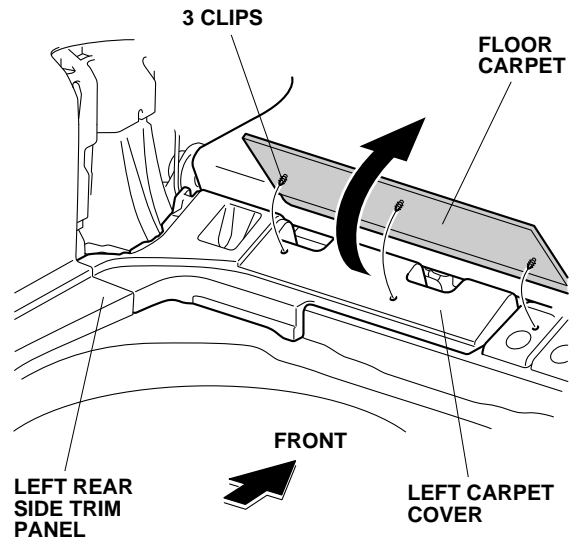

11. Remove the left carpet cover (three clips and two retaining tabs).

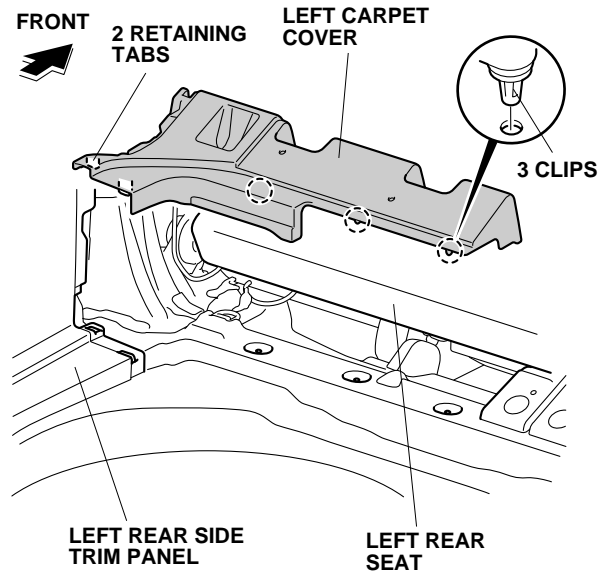

12. Gently pull the lever on the left rear side trim panel and use a small flat-tip screwdriver wrapped with a shop towel to remove the inner handle cap (one tab and two hooks).

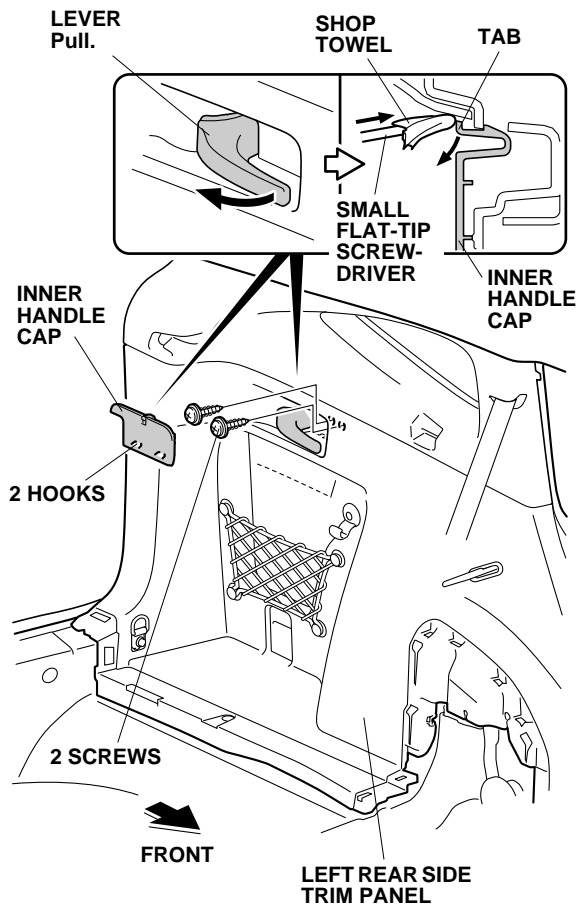

13. Remove two screws.

14. Press the center of the hook to remove the hook from the left rear side trim panel.

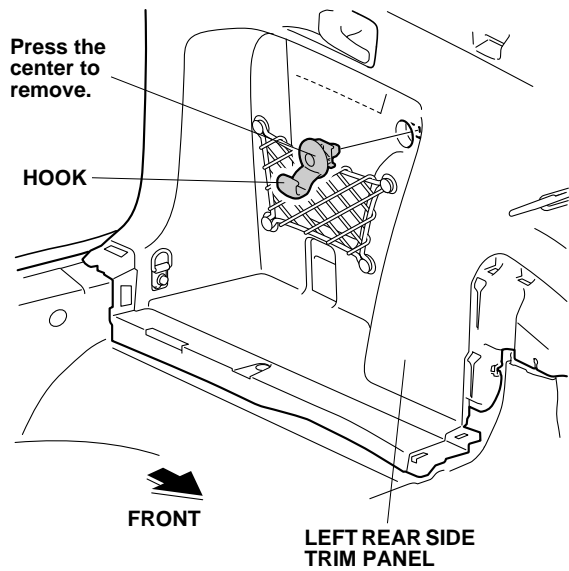

15. Remove the tiedown hook (one bolt).

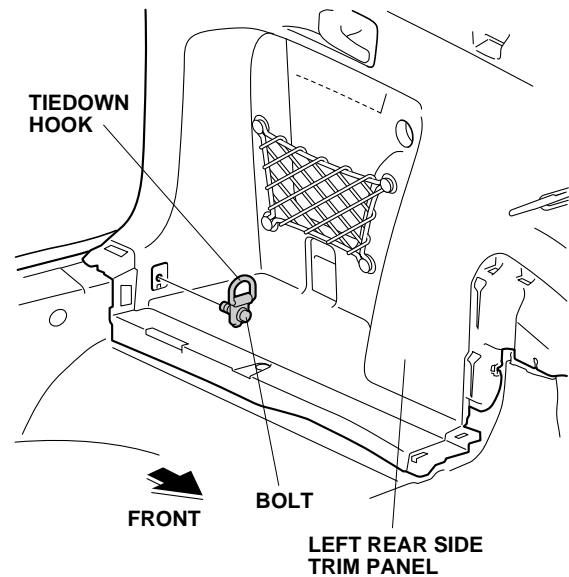

- Pull away the weatherstrip from the left rear side trim panel at the tailgate opening, and pull away the left rear door opening seal. Starting at the front, release the left rear side trim panel (eight clips and seven retaining tabs).

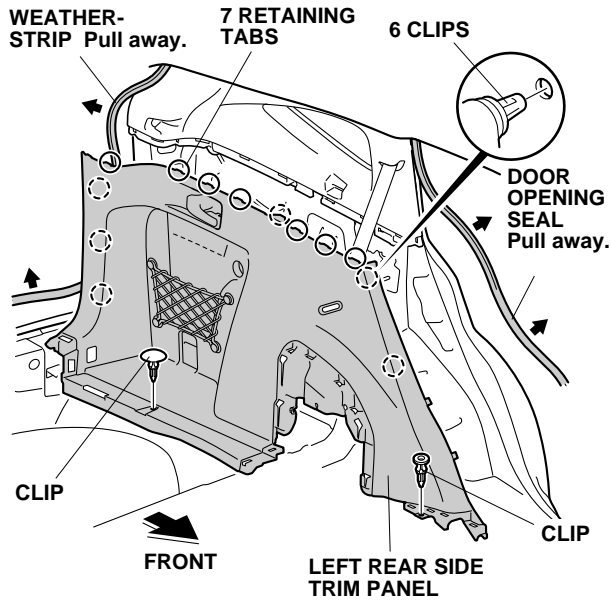

- Release the cable, then remove the left rear seat release lever (two clips and five retaining tabs). Remove the left rear side trim panel.

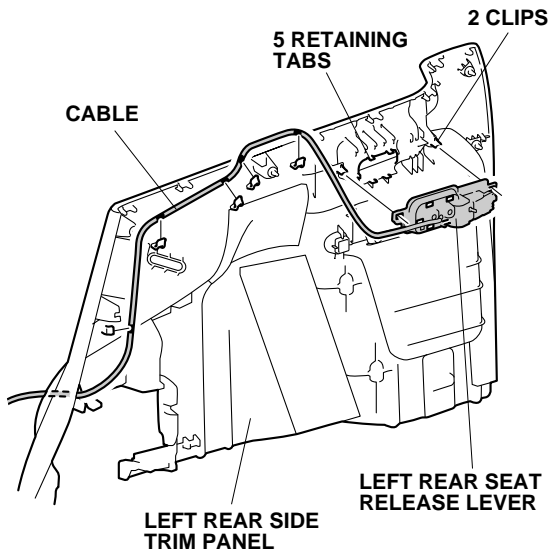

- Pull away the door opening seal from the left D-pillar trim.

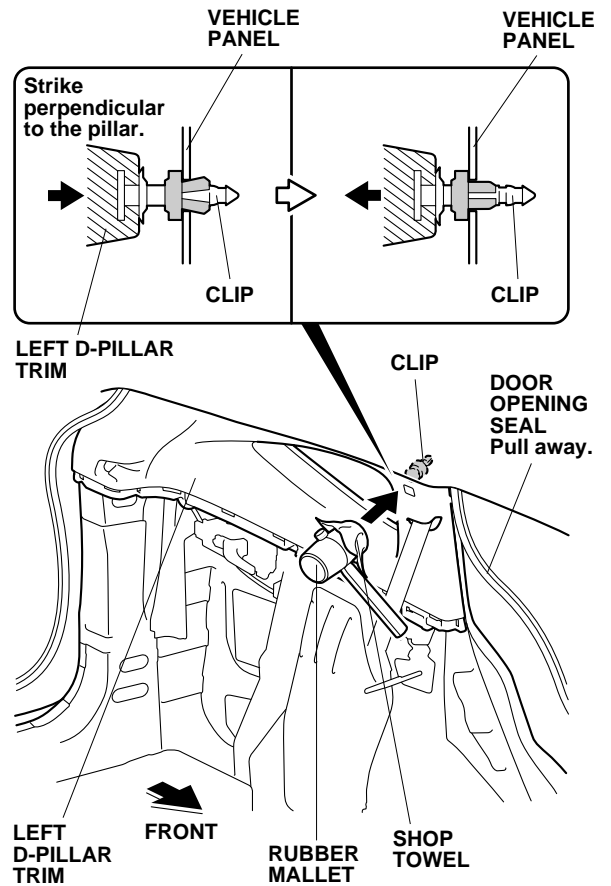

- Using a rubber mallet wrapped with a shop towel, lightly tap the area marked "SIDE CURTAIN AIRBAG" on the left D-pillar trim to push in the clip. Make sure to tap perpendicular to the pillar.

20. Remove the left D-pillar trim (ten clips).

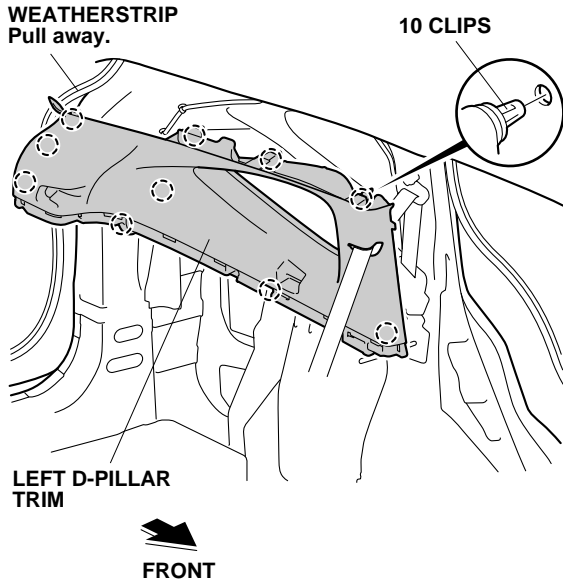

21. Open the right rear door.
22. Remove one clip and two screws from the right rear wheel arch protector. If equipped, remove the splash guards.

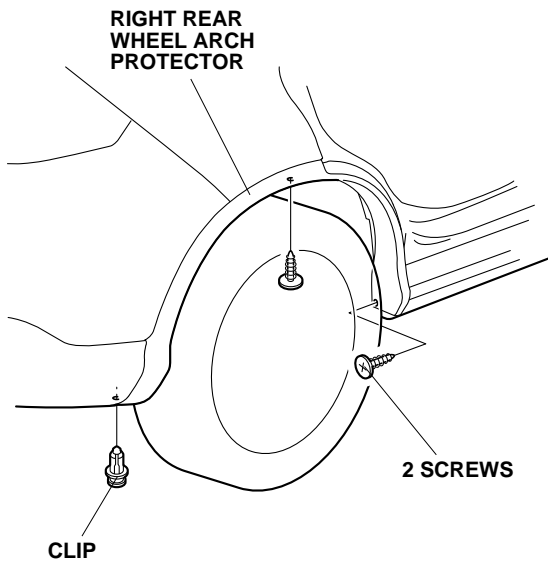

23. Remove the right rear wheel arch protector (eleven clips and two retaining tabs).

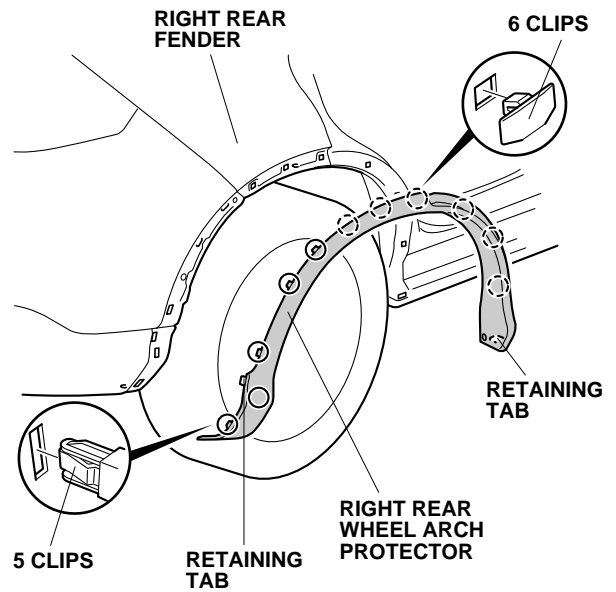

24. Repeat steps 22 and 23 to remove the left rear wheel arch protector.
25. Apply masking tape to the rear bumper, taillight, and rear fender on each side of the vehicle.

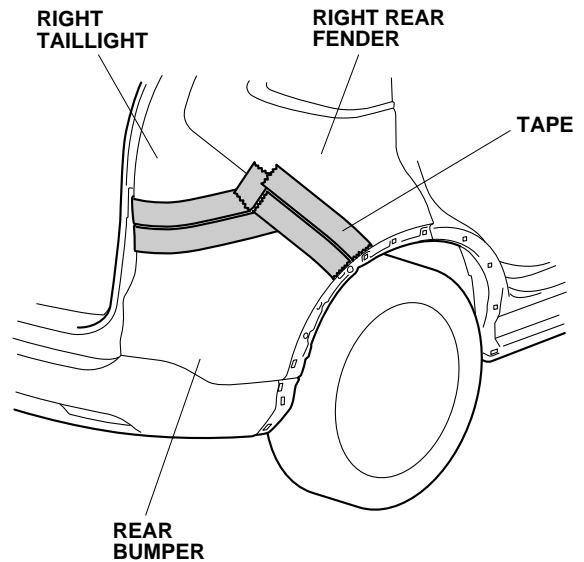

26. Remove the rear bumper.

- Remove the two covers, two bumper screws, two bolts, two screws, and five clips.

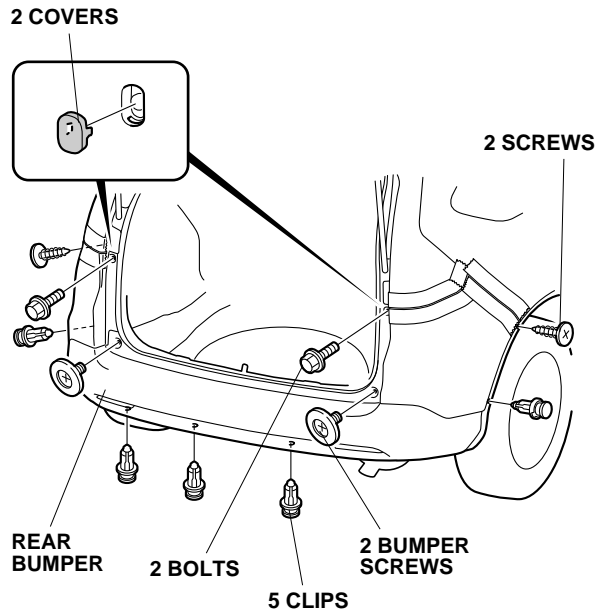

- Release five retaining tabs along the fenderwell on each side.

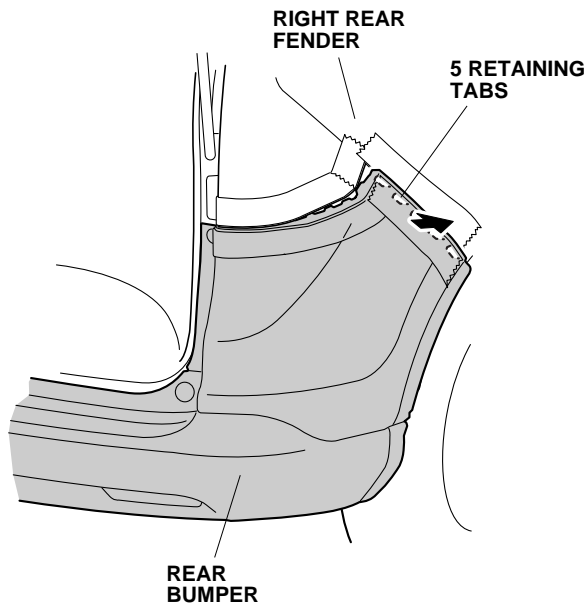

- Release four retaining tabs on each side.

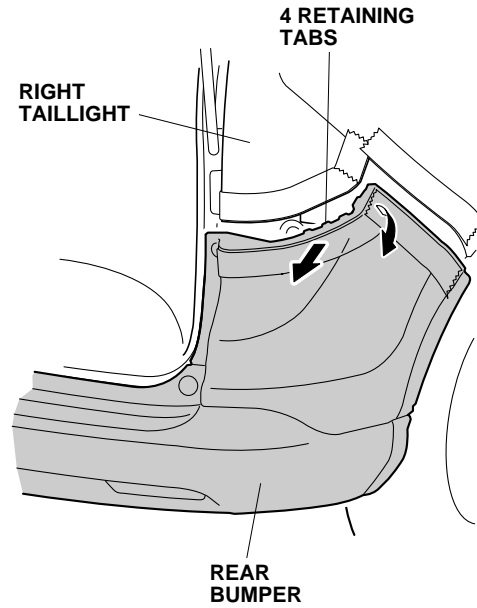

- With the help of an assistant, remove the rear bumper. Place the rear bumper on a blanket.

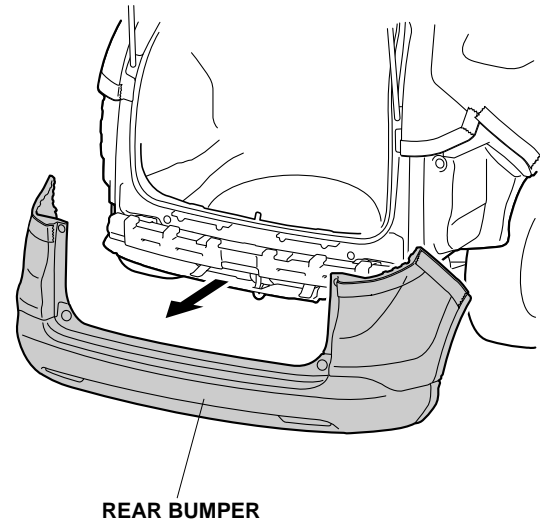

27. Remove the bumper absorber.

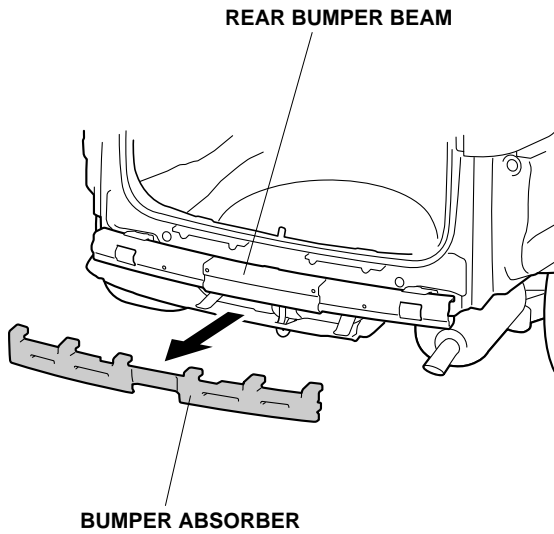

28. Using isopropyl alcohol on a shop towel, thoroughly clean the fuse case where the fuse label will attach. Attach the 2A fuse label to the fuse case on the backup sensor harness.

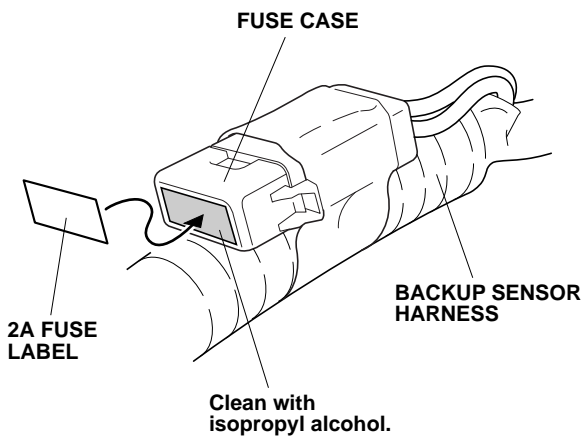

29. Locate and remove the lower vehicle grommet in the left rear of the cargo area.

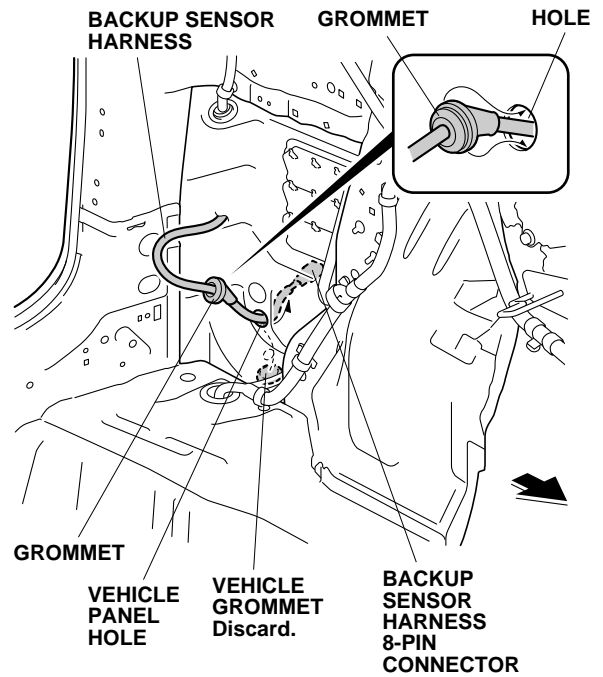

30. Route the backup sensor harness 8-pin connector through the hole, and set the backup sensor harness grommet into the vehicle panel hole. Do not pull on the backup sensor harness.
31. Adjust the volume control knob on the control unit. Do not turn the knob excessively. That may damage the control unit

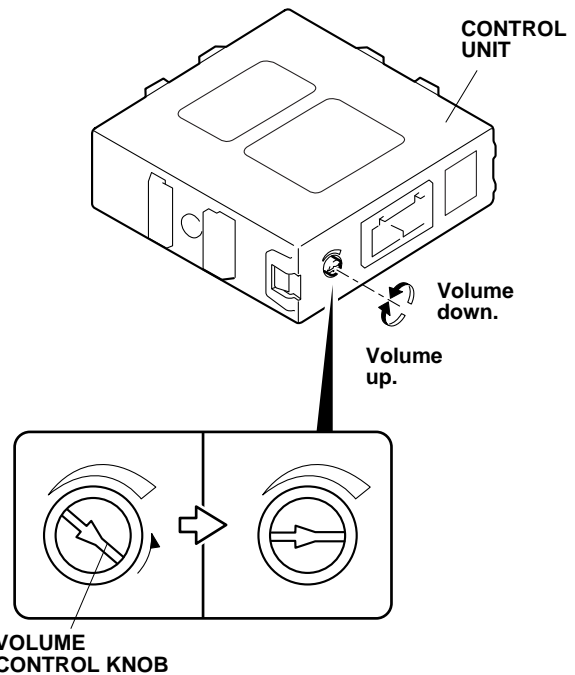

32. Using isopropyl alcohol on a shop towel, thoroughly clean the control unit where the urethane tape will attach.

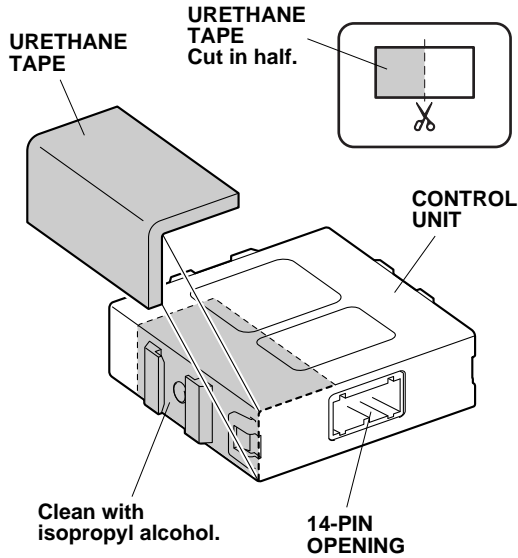

33. Using scissors, cut one urethane tape in half. Attach the cut piece of urethane tape to the control unit in the area shown.
34. Install the control unit bracket onto the control unit.

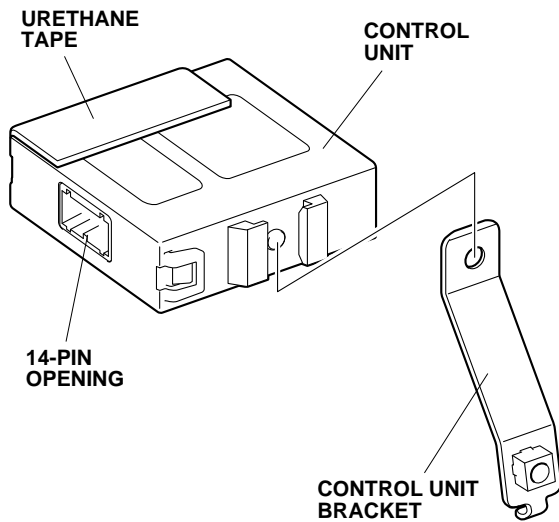

35. Using isopropyl alcohol on a shop towel, thoroughly clean the control unit where the urethane tape will attach. Attach the remaining half of urethane tape (cut in step 33) to the control unit in the area shown.

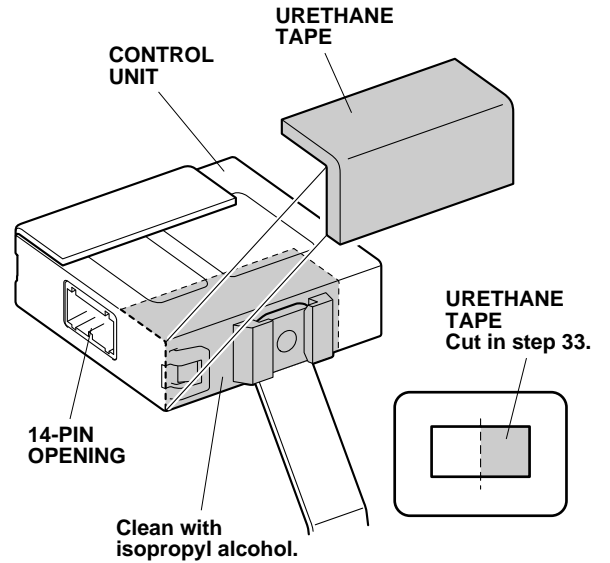

36. Insert the control unit bracket into the hole in the vehicle panel, and secure it with one flange bolt.

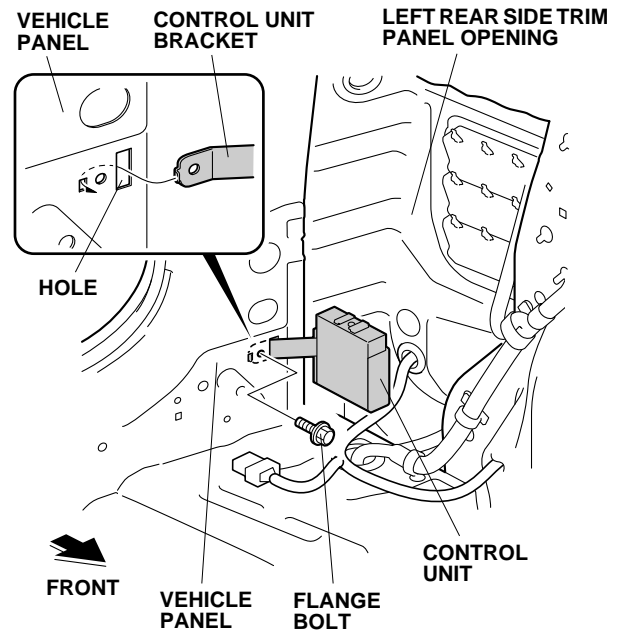

37. Plug the backup sensor harness 14-pin connector into the control unit.

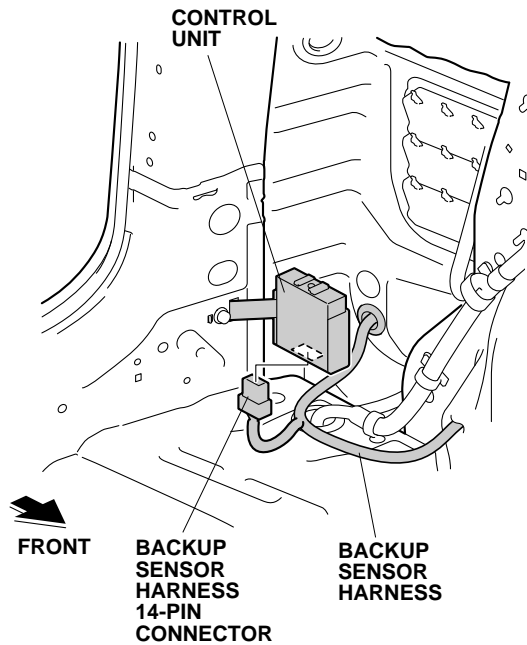

If the vehicle is equipped with a vehicle harness, continue with step 38. If not, go to step 40.

With Vehicle Harness

38. Using isopropyl alcohol on a shop towel, thoroughly clean the vehicle panel where the aluminum tape will attach. Secure the backup sensor harness to the vehicle panel with one aluminum tape.

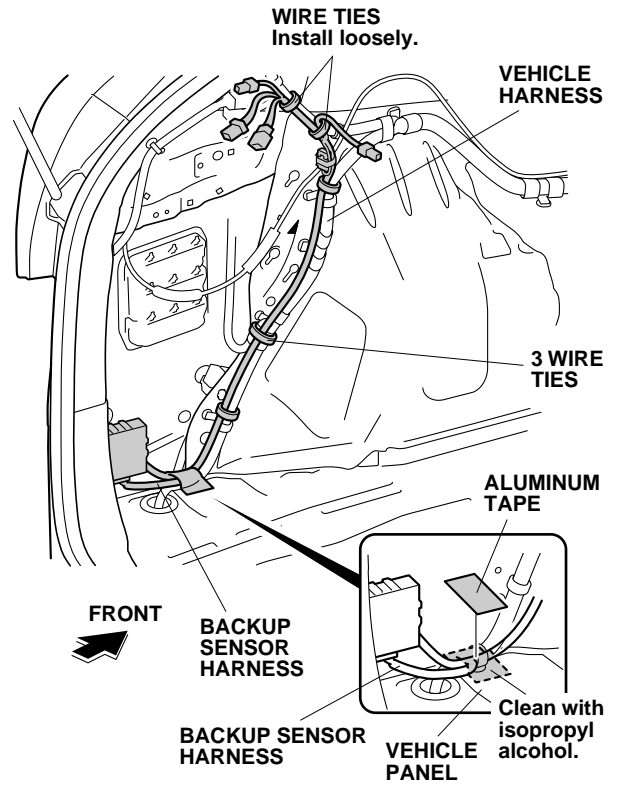

39. Route the backup sensor harness along the vehicle harness. Secure it to the vehicle harness with five loosely-installed wire ties as shown. Go to step 42.

Without Vehicle Harness

40. Using isopropyl alcohol on a shop towel, thoroughly clean the vehicle panel where the aluminum tape will attach. Secure the backup sensor harness to the vehicle panel with one aluminum tape.

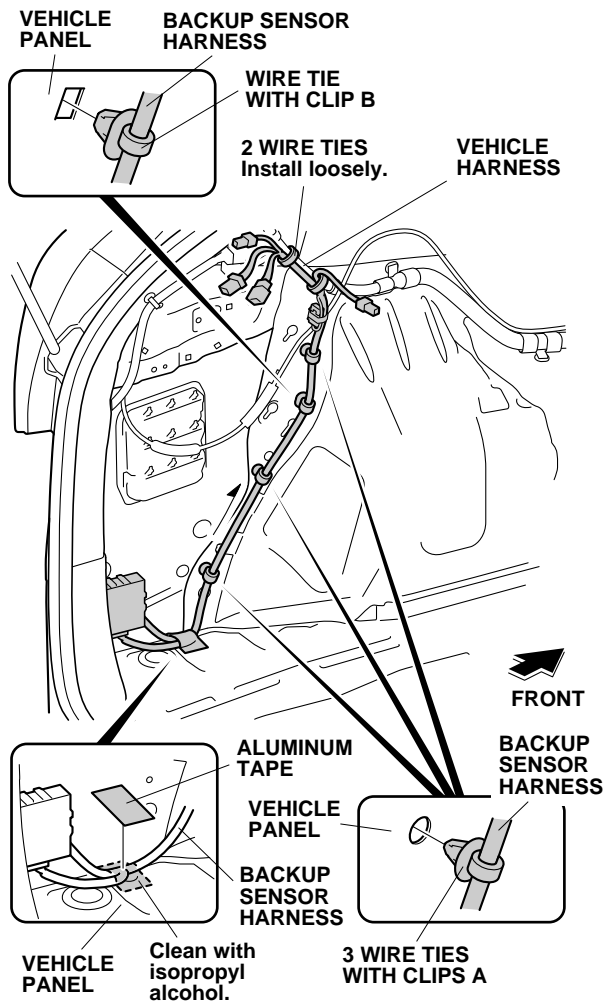

41. Route the backup sensor harness along the vehicle harness. Secure it to the vehicle panel and vehicle harness with three wire ties with clips A, one wire tie with clip B, and two loosely-installed wire ties.

42. Unplug the vehicle 13-pin connector.

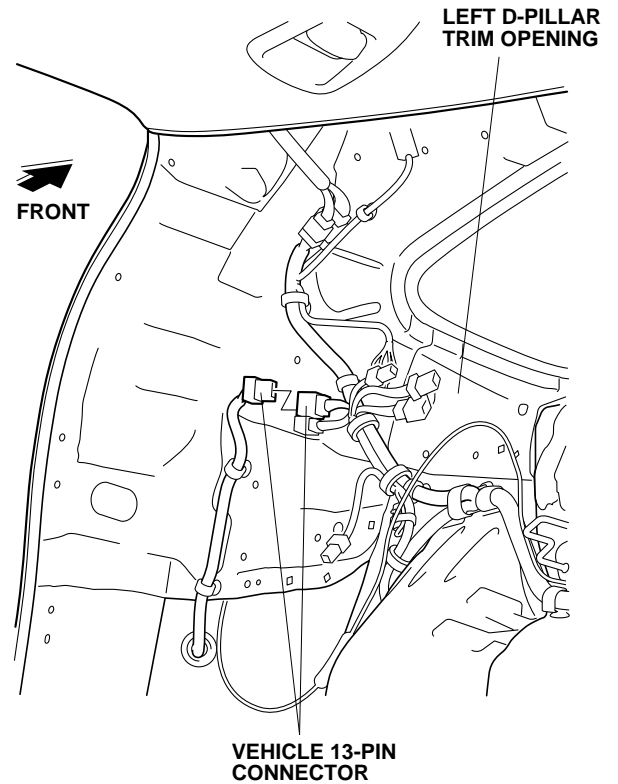

43. Slide the clip on the backup sensor harness 13-pin connector onto the vehicle connector clip.

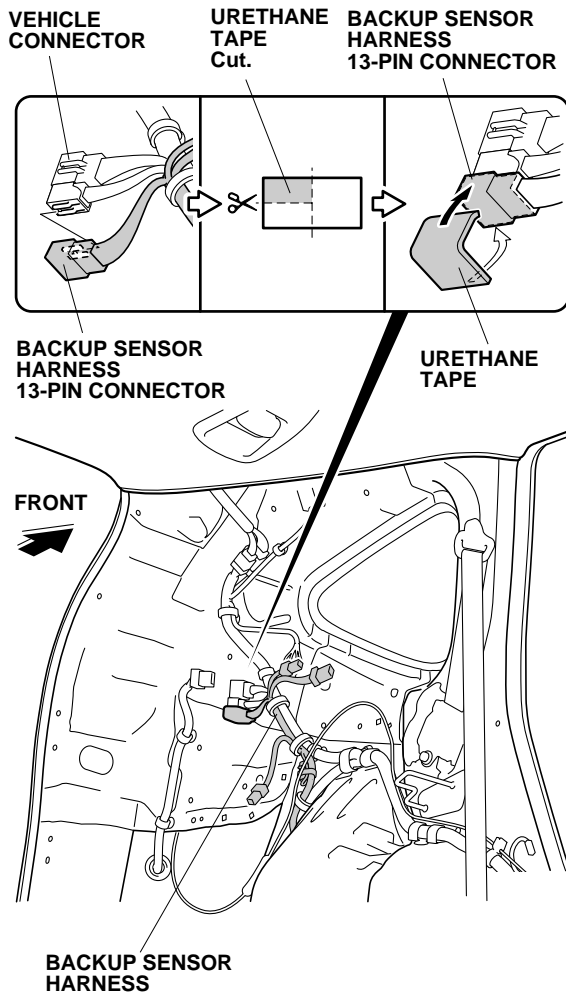

44. Using scissors, cut one urethane tape as shown. Attach the cut piece of urethane tape to the backup sensor harness 13-pin connector.

If the vehicle is equipped with a trailer hitch harness, continue with step 45. If not, go to step 48.

With Trailer Hitch Harness

45. Unplug the trailer hitch harness 13-pin connector.

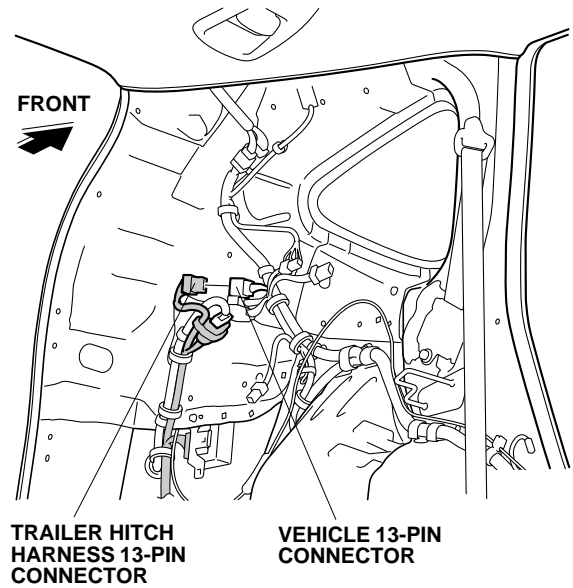

46. Plug the backup sensor harness 13-pin connector into the vehicle 13-pin connector.

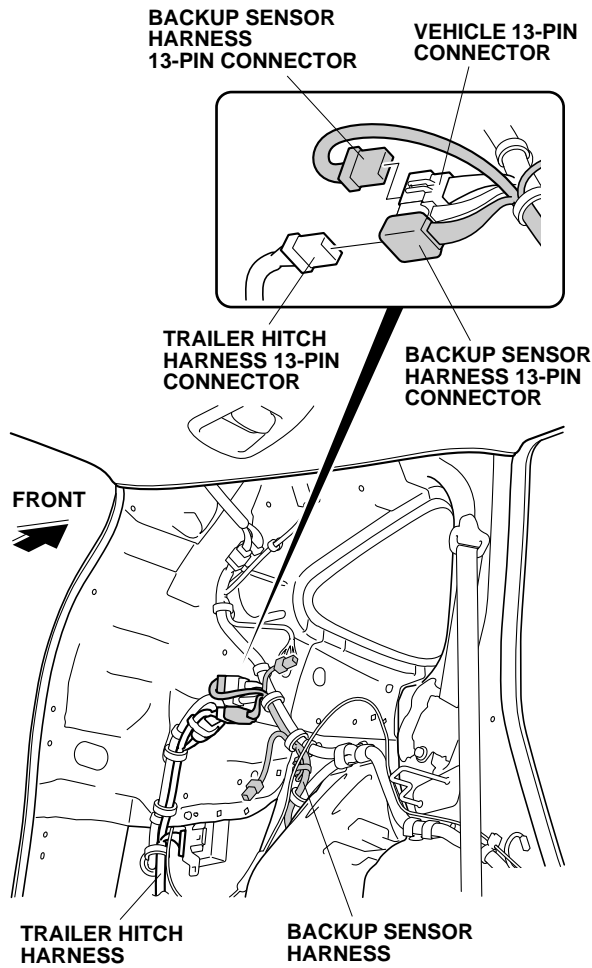

47. Plug the trailer hitch harness 13-pin connector into the backup sensor harness 13-pin connector. Go to step 50.

Without Trailer Hitch Harness

48. Plug the backup sensor harness 13-pin connector into the vehicle 13-pin connector.

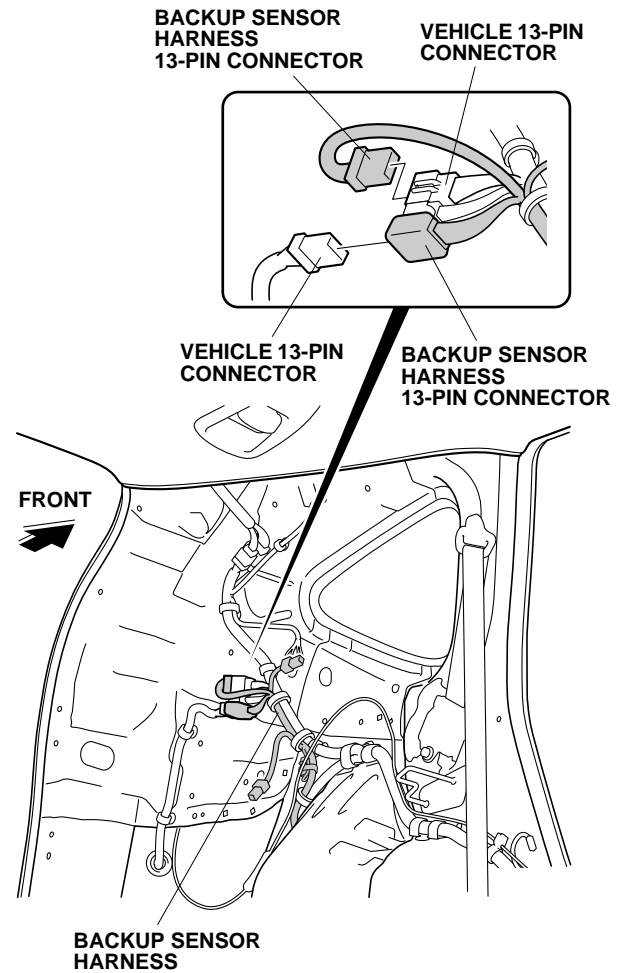

49. Plug the vehicle 13-pin connector into the backup sensor harness 13-pin connector.

50. Using isopropyl alcohol on a shop towel, thoroughly clean the vehicle panel where the buzzer will attach.

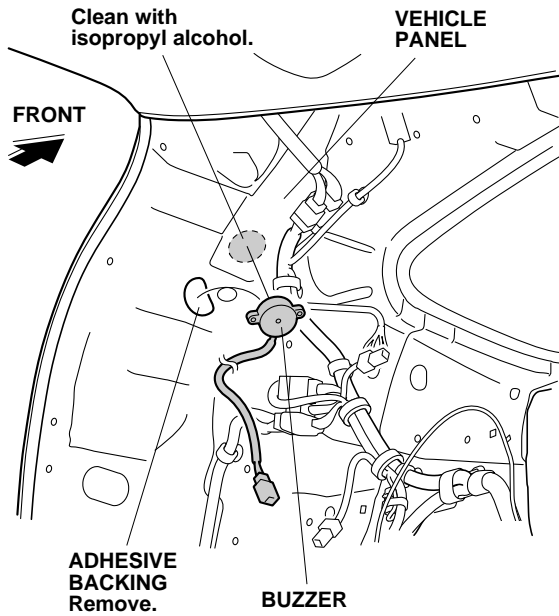

51. Remove the adhesive backing from the buzzer and attach the buzzer to the vehicle panel in the location shown.

52. Plug the buzzer 2-pin connector into the backup sensor harness 2-pin connector.

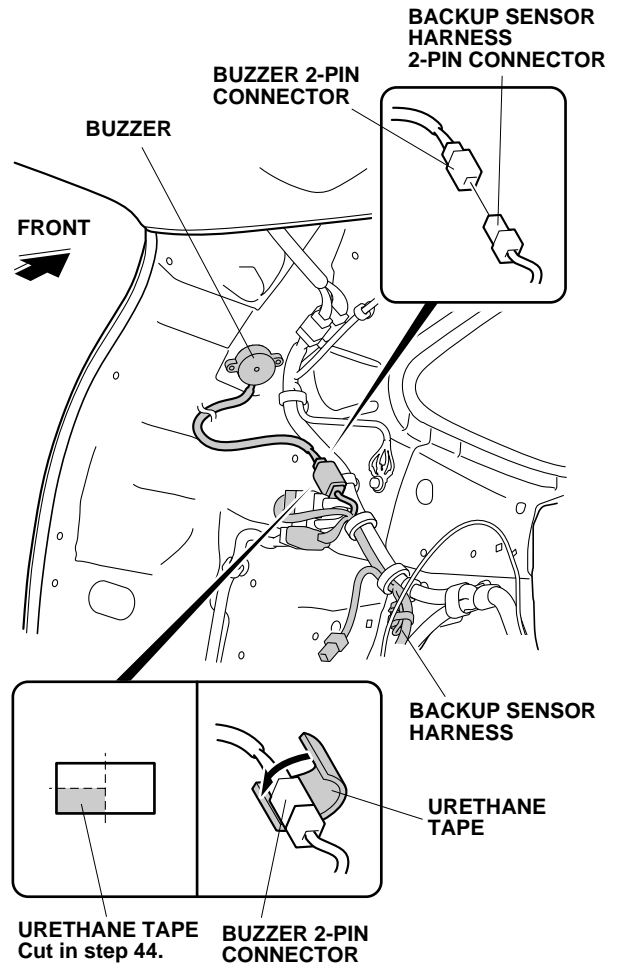

53. Attach the other piece of urethane tape (cut in step 44) around the buzzer 2-pin connector.

54. Bundle up the excess buzzer harness and secure the buzzer harness and 2-pin connectors to the vehicle harness with the two wire ties that were loosely installed in step 39 or 41.

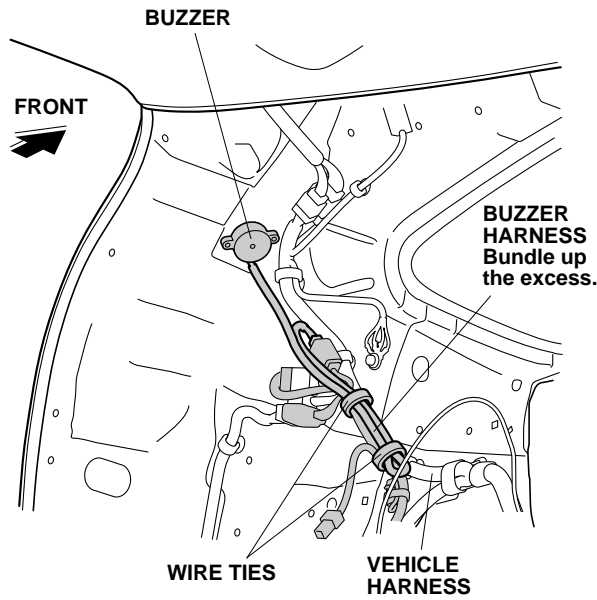

55. Using a ruler and a felt-tip pen, measure and mark the inside of the left rear side trim panel in the area shown.

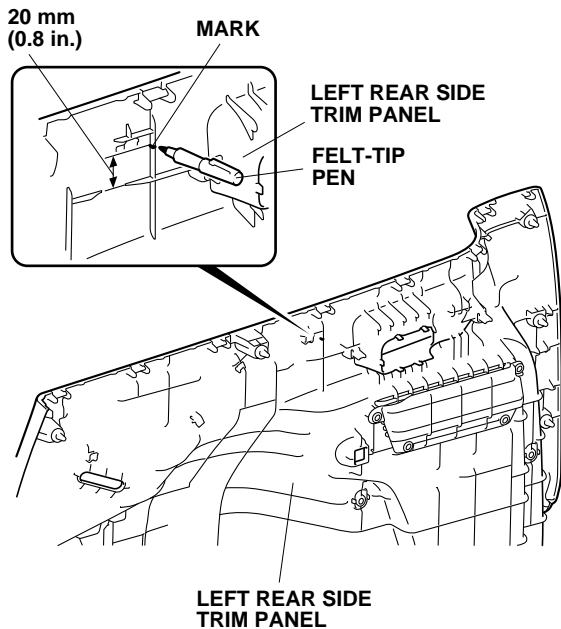

56. Using a utility knife, cut out the ribs on the left rear side trim panel. Remove any burrs.

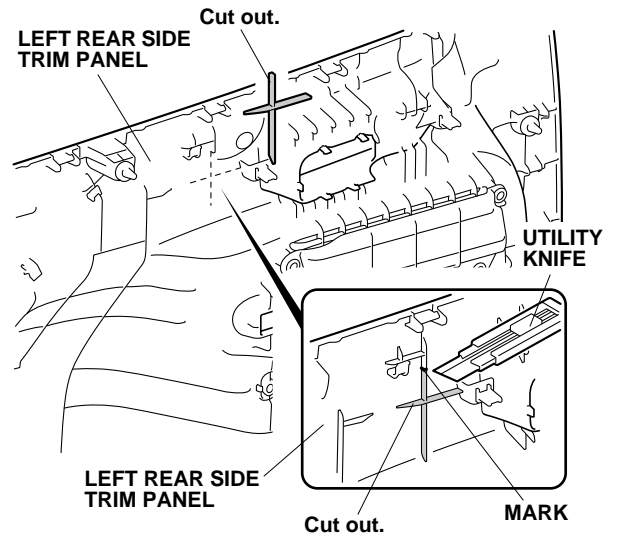

57. Using a pushpin, pierce the left rear side trim panel at the location shown.

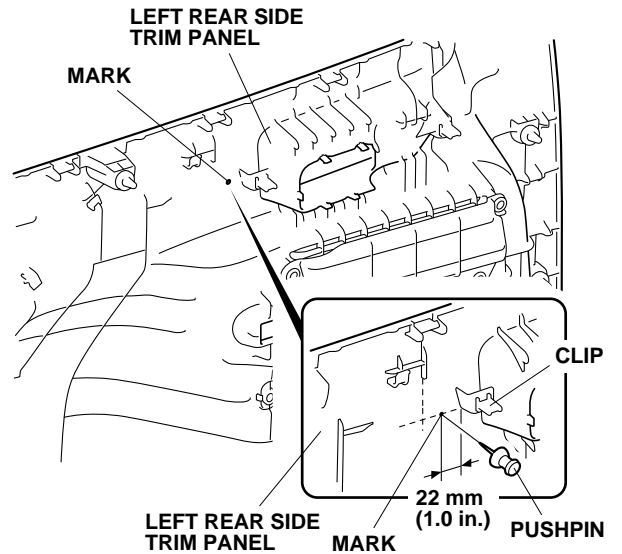

58. While wearing eye protection, drill the pierced mark with a 3 mm drill bit. Enlarge the hole with a 26 mm hole saw. Remove any burrs.

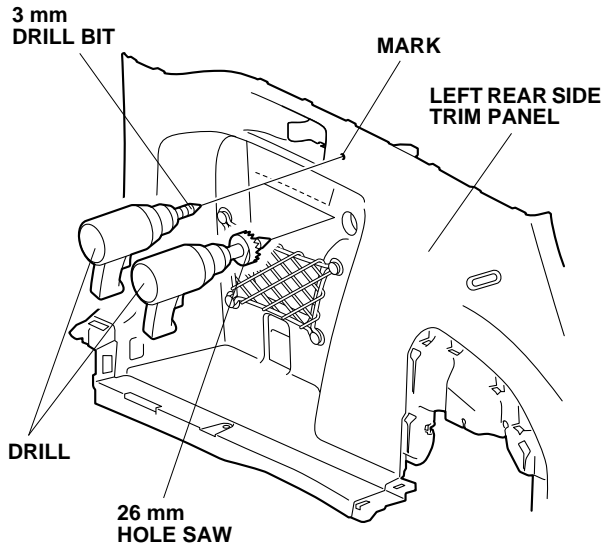

59. Install the switch into the 26 mm hole in the left rear side trim panel. Make sure the switch is installed right side up.

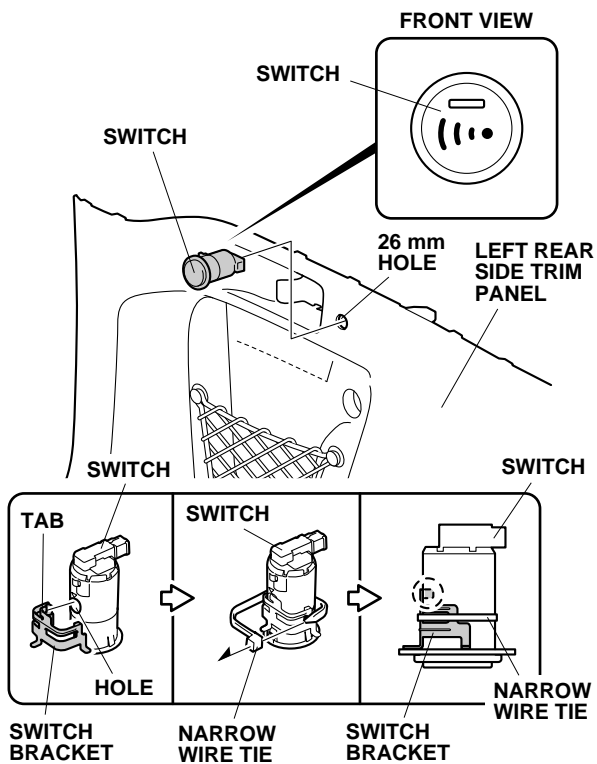

60. Align the tab on the switch bracket with the hole in the switch, and secure the switch bracket to the switch with one narrow wire tie. Firmly press the switch bracket against the left rear side trim panel, and make sure there is no clearance between the switch and the left rear side trim panel.
61. Remove and discard the vehicle clip, and install the new clip to the left D-pillar trim.

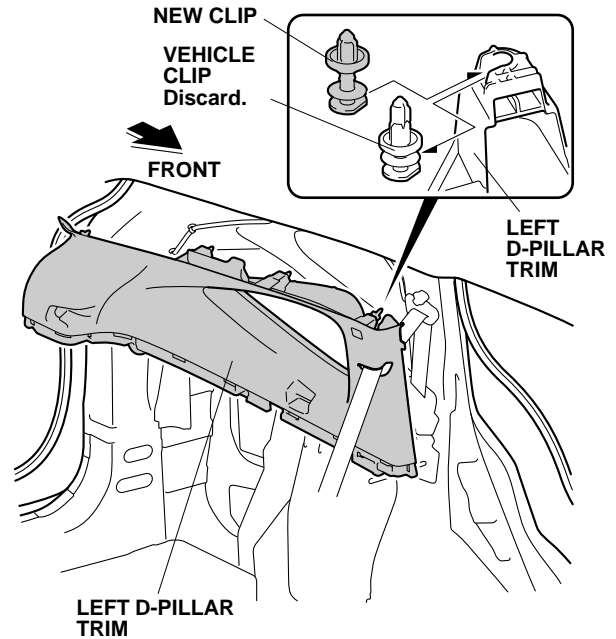

62. Check the overlap between the headliner and the D-pillar trim. If necessary, adjust the overlap as shown in the service manual.
63. Reinstall the left D-pillar trim.
NOTE: Make sure the side curtain airbag is not pinched under the clip. Do not use force on the D-pillar trim.

64. Bring the left rear side trim panel into position. Plug the backup sensor harness 3-pin connector into the switch. Reinstall the left rear seat release lever and the left rear side trim panel.

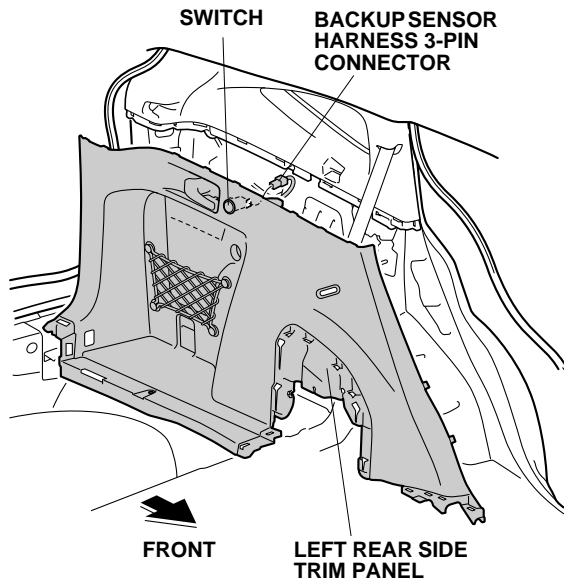

65. Mark the inside of the rear bumper:
- Locate the four scribe marks on the inside of the bumper at the center and on each side.
 - Using a pushpin, pierce the rear bumper at the top and center of each of the four marks. Pierce the scribe marks perpendicular to the surface. **NOTE:** There are several marks on the inside of the rear bumper. Before piercing, make sure you have the correct locations.

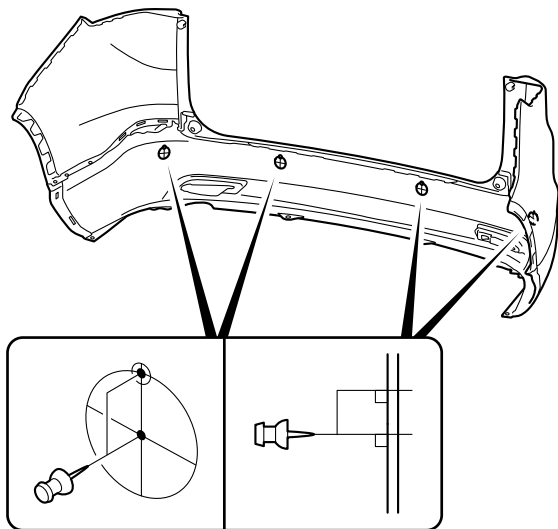

66. While wearing eye protection, drill the eight pierced marks with a 3 mm drill bit. Work from the painted side of the rear bumper. Drill perpendicular to the rear bumper.

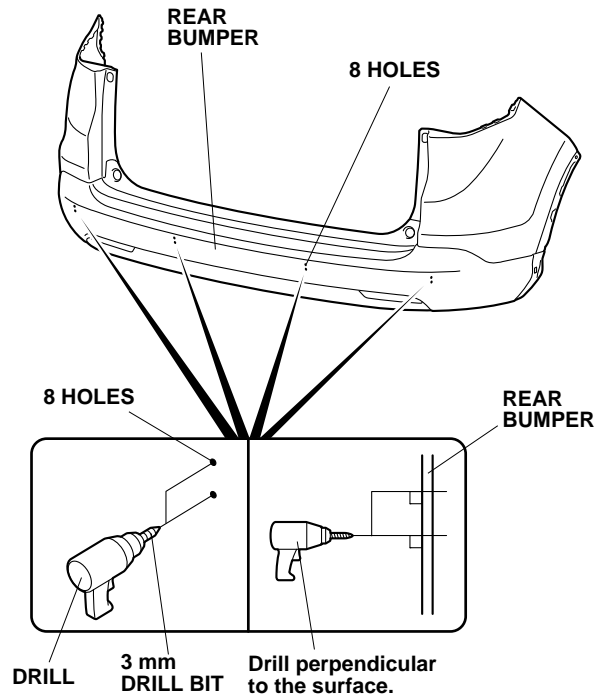

67. While wearing eye protection, enlarge the two lower outer holes with a 24 mm hole saw. Drill perpendicular to the rear bumper. Remove any burrs.

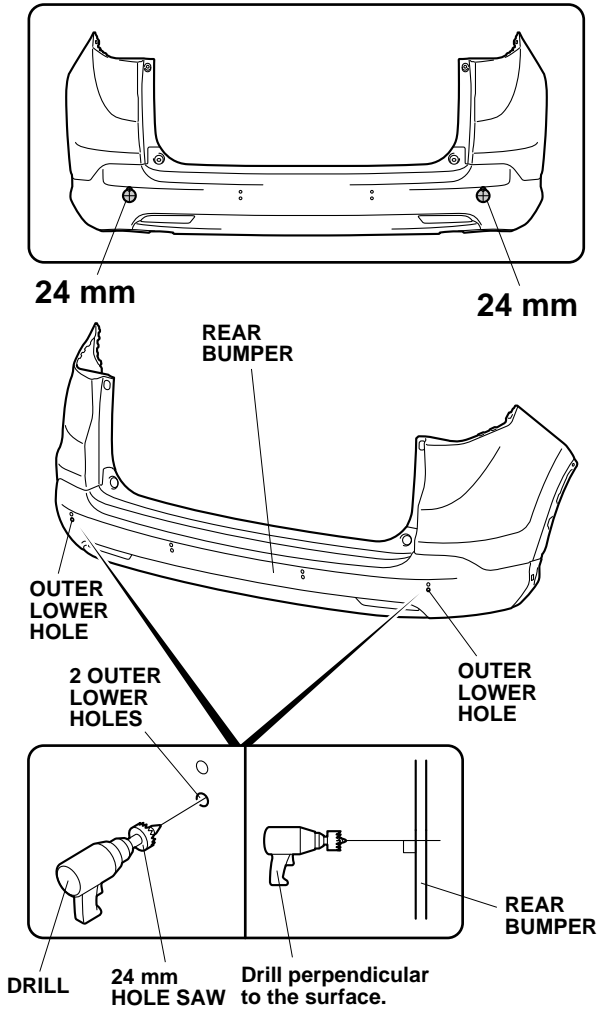

68. While wearing eye protection, enlarge the two lower inner holes with a 26 mm hole saw. Drill perpendicular to the rear bumper. Remove any burrs.

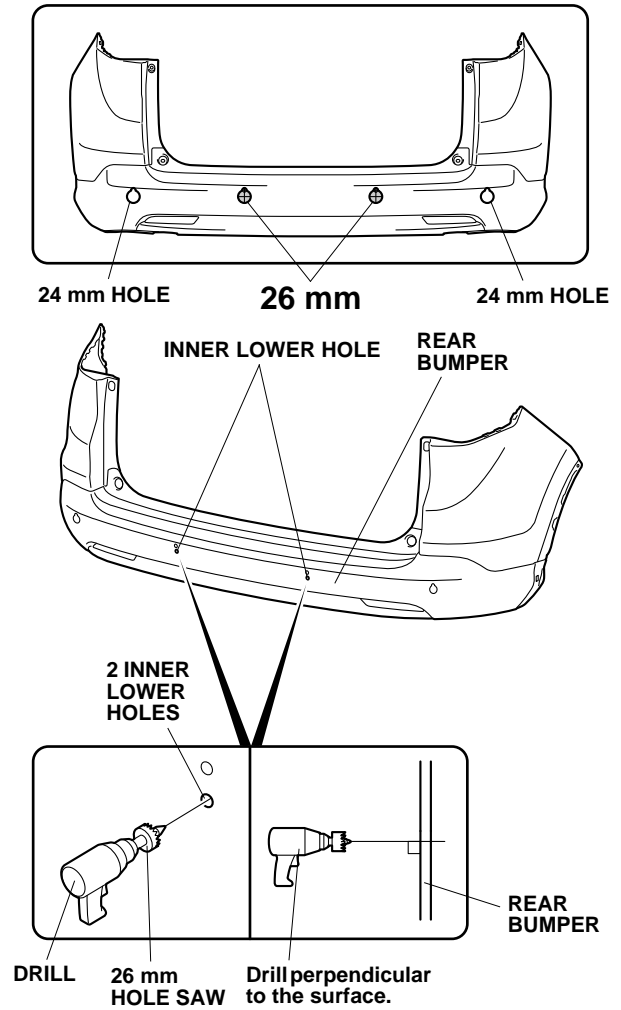

69. Insert the left corner sensor (white) and the left center sensor (blue) into the rear bumper.
NOTE: The left corner sensor (white) and the left center sensor (blue) have the yellow dot.

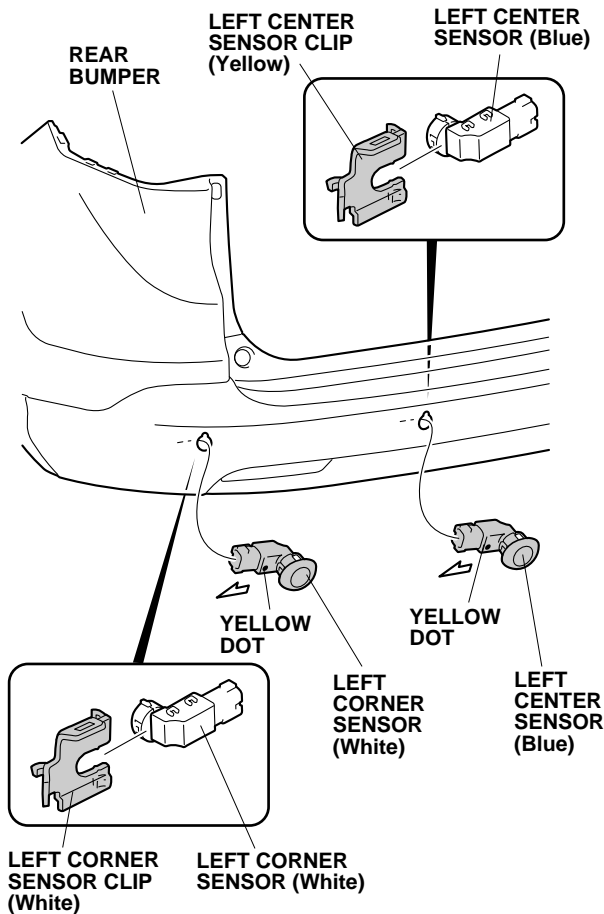

70. Secure the left corner sensor (white) and the left center sensor (blue) with the left corner sensor clip (white) and the left center sensor clip (yellow) as shown.

71. Insert the right corner sensor (white) and the right center sensor (blue) into the rear bumper.

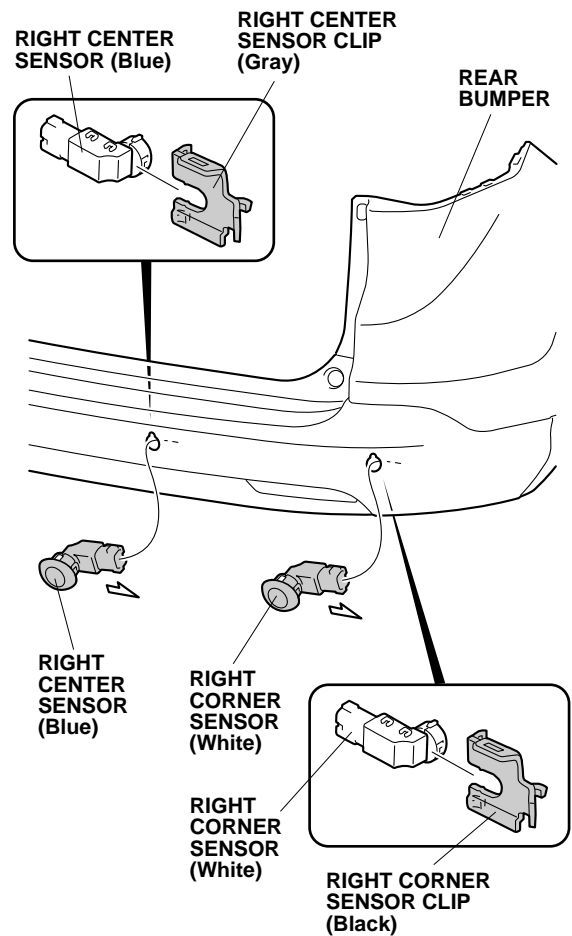

72. Secure the right corner sensor (white) and the right center sensor (blue) with the right corner sensor clip (black) and the right center sensor clip (gray) as shown.

73. Plug four subharness 2-pin connectors into the right center sensor (blue), left center sensor (blue), right corner sensor (white) and left corner sensor (white).

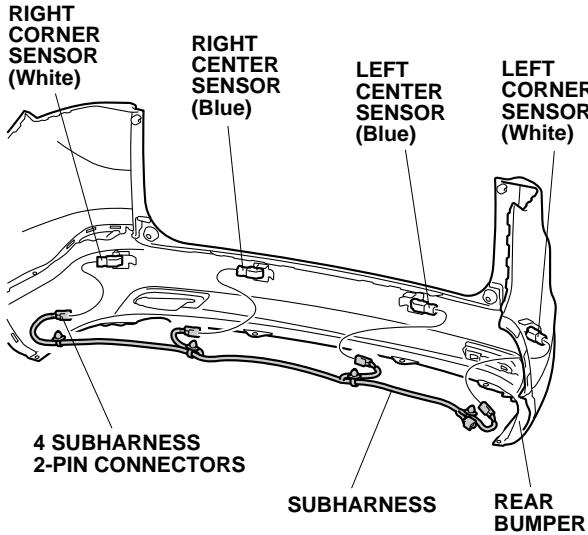

74. Secure the four backup sensor clips into the four sensor clips.

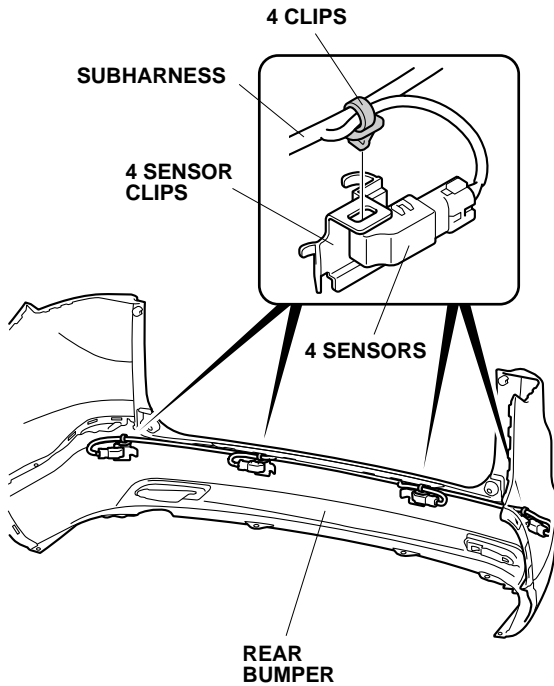

75. On the inside of the rear bumper, use isopropyl alcohol on a shop towel to thoroughly clean the rear bumper where the aluminum tapes will attach.

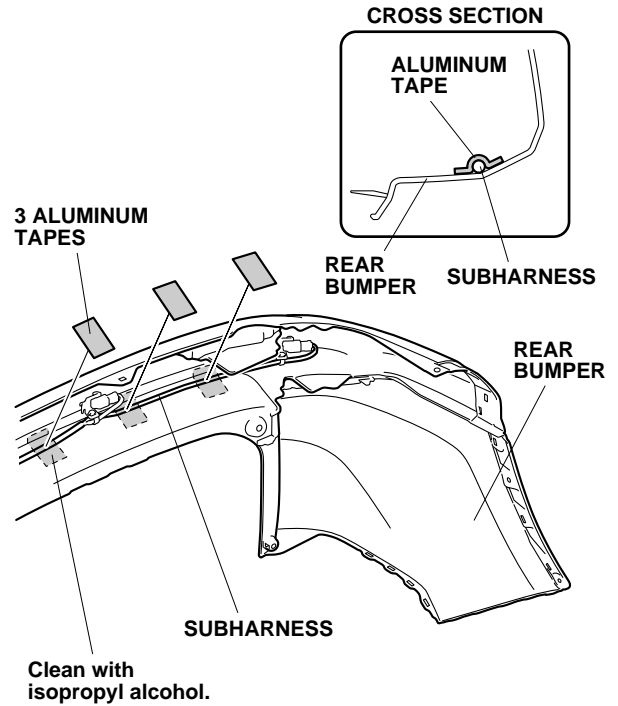

76. Secure the subharness to the rear bumper with three aluminum tapes at the areas shown.

77. Using isopropyl alcohol on a shop towel, thoroughly clean the other side of the rear bumper where the aluminum tapes will attach.

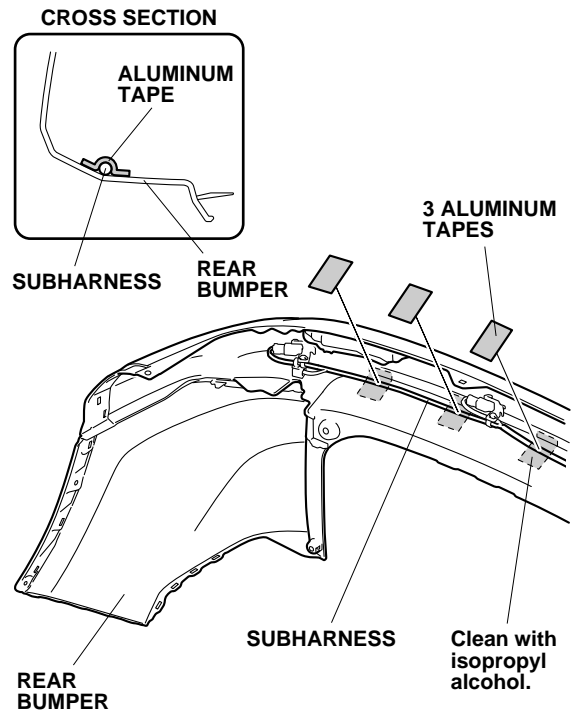

78. Secure the subharness to the rear bumper with three aluminum tapes in the areas shown.
79. Using a utility knife, cut out the bumper absorber along the scribe lines.

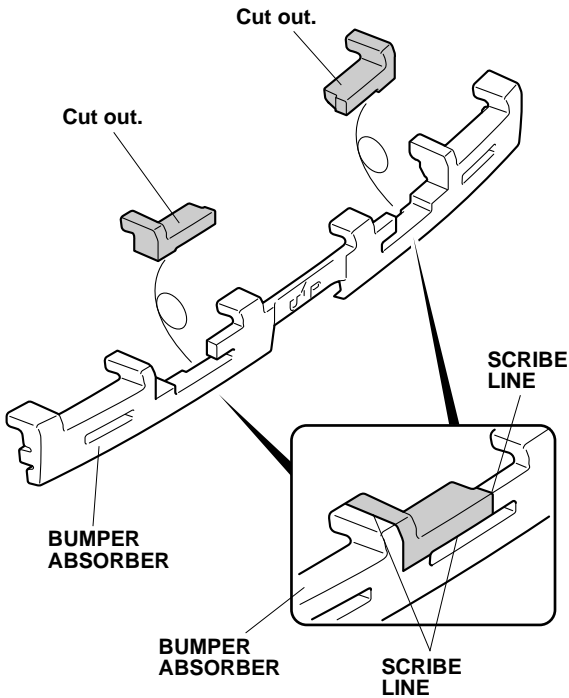

80. Reinstall the bumper absorber to the rear bumper beam.

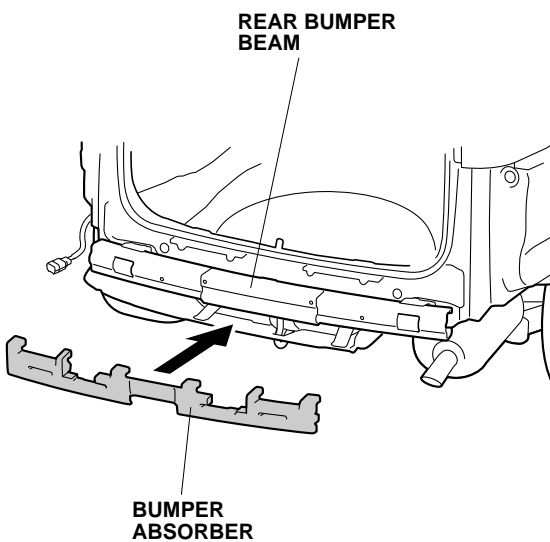

81. With the help of an assistant, bring the rear bumper to the vehicle, and plug the backup sensor harness 8-pin connector into the subharness 8-pin connector. Reinstall the rear bumper.

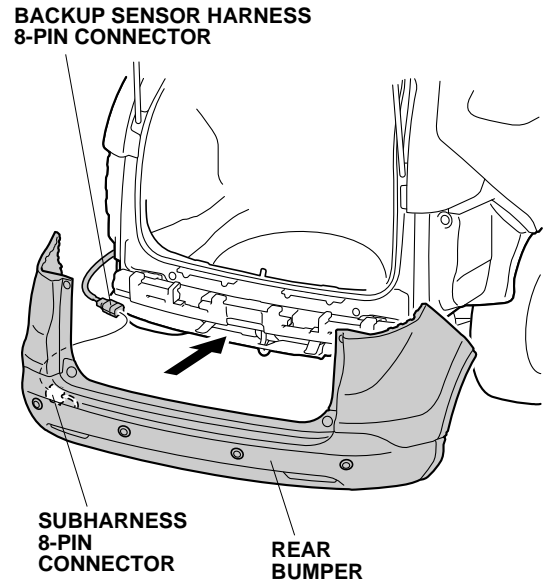

82. Check that all wire harnesses are routed properly and that all connectors are plugged in.
83. Reconnect the negative cable to the battery.
84. Press and hold the radio power button for two seconds to restore the radio and navi (if equipped) system functions.
85. Reset the clock (vehicles without navigation).
86. Reinstall all removed parts.
87. Check that the backup sensors work properly as shown in the Accessory User's Information Manual supplied with the backup sensor kit.

Buzzer Volume Control

After checking the operation of the system, adjust the volume, if necessary, by turning the volume control knob on the control unit using a small flat-tip screwdriver.

